

# QUADRO DE PROTEÇÃO CA (QDCA/118)

QUADRO DE PROTEÇÃO  
E ISOLAMENTO DA REDE

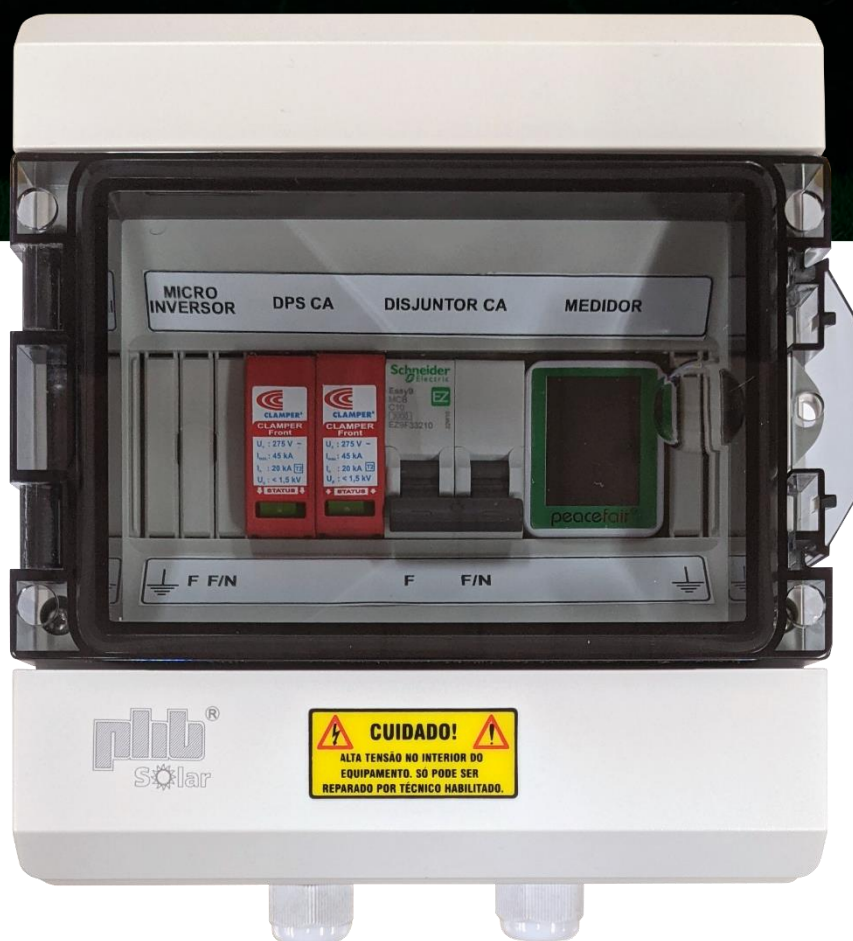

**Dimensões**

197X210X95mm (L X A X P)



Rua São Bernardino nº 12  
Pq. Anhanguera - CEP: 05120-050  
São Paulo - SP



(11) 3648-7830  
contato@phb.com.br



# Composição do quadro de proteção CA.

Modelo	QDCA/118
Tensão de Entrada	220/127 Vca
Dimensões	197X210X95mm (L X A X P)
Grau de proteção	IP65
Dispositivo de proteção contra surto	(2) DPS classe II com IEC 61643-11 I <sub>max</sub> 45kA. Tensão máxima de operação contínua: 275Vca
Disjuntor	(1) Bipolar Curva C 10A
Medidor Digital	Medidas: tensão, corrente, potência e energia

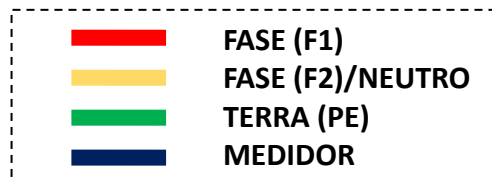
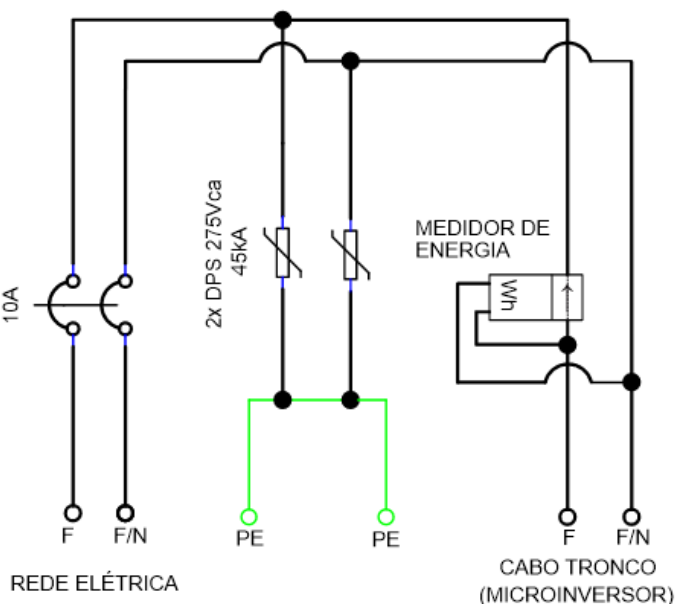
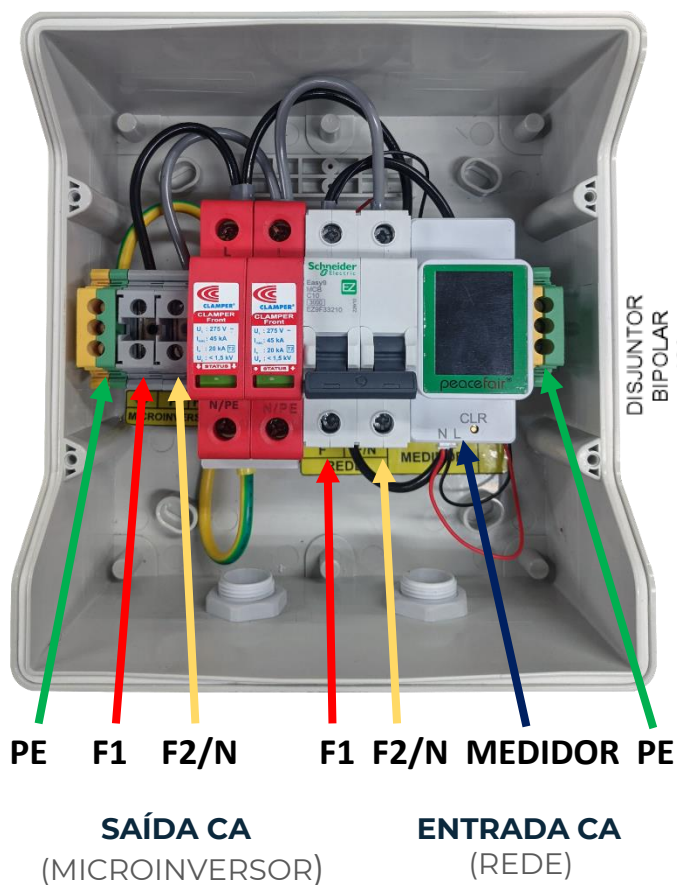

Rua São Bernardino nº 12  
Pq. Anhanguera - CEP: 05120-050  
São Paulo - SP



(11) 3648-7830  
contato@phb.com.br

