

QUADRO DE PROTEÇÃO CA (QDCA/131)

QUADRO DE PROTEÇÃO E ISOLAMENTO DA REDE



Dimensões

310X230X95mm (L X A X P)



Rua São Bernardino nº 12
Pq. Anhanguera - CEP: 05120-050
São Paulo - SP



(11) 3648-7830
contato@phb.com.br



Composição do quadro de proteção CA.

Modelo	QDCA/131
Tensão de Entrada	380/220Vca
Dimensões	310X230X95mm (L X A X P)
Grau de proteção	IP65
Dispositivo de proteção contra surto	(4) DPS classe II com IEC 61643-11 I _{max} 40kA. Tensão máxima de operação contínua: 275Vca
Disjuntor	(1) Tripolar Curva C 63A



PE L2 L3 L3 N
SAÍDA CA
(INVERSOR)

L1 L2 L3 N PE
ENTRADA CA
(REDE)

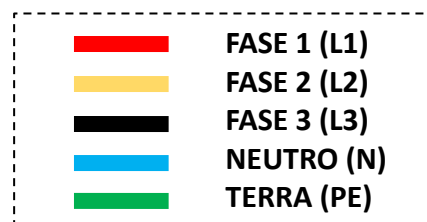
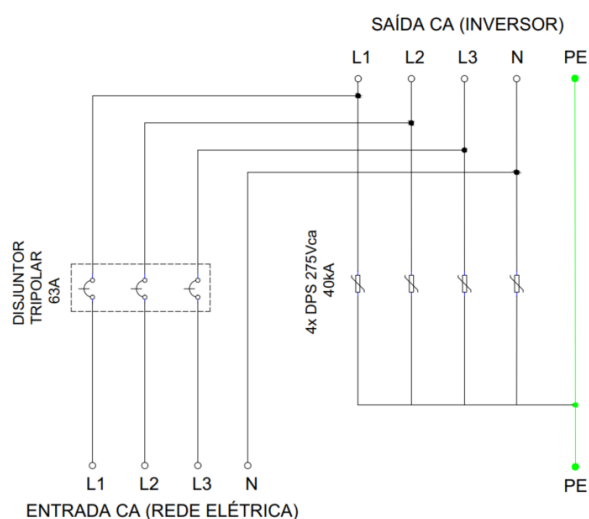

Rua São Bernardino nº 12
Pq. Anhanguera - CEP: 05120-050
São Paulo - SP



(11) 3648-7830
contato@phb.com.br

