

# QUADRO DE PROTEÇÃO CA (QDCA/69)

QUADRO DE PROTEÇÃO E SECCIONAMENTO DA REDE



**Dimensões**

310X230X110mm (L X A X P)



Rua São Bernardino nº 12  
Pq. Anhanguera - CEP: 05120-050  
São Paulo - SP



(11) 3648-7830  
contato@plb.com.br

**plb**<sup>®</sup>  
Solar

# Composição do quadro de proteção CA.

Modelo	QDCA/69
Tensão de Entrada	220/127Vca
Dimensões	310X230X110mm (L X A X P)
Grau de proteção	IP65
Dispositivo de proteção contra surto	(4) DPS classe II com IEC 61643-11 I <sub>max</sub> 45kA. Tensão máxima de operação contínua: 275Vca
Disjuntor	(1) Tripolar Curva C 50A

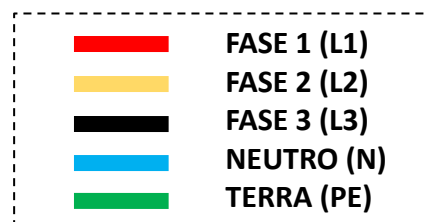
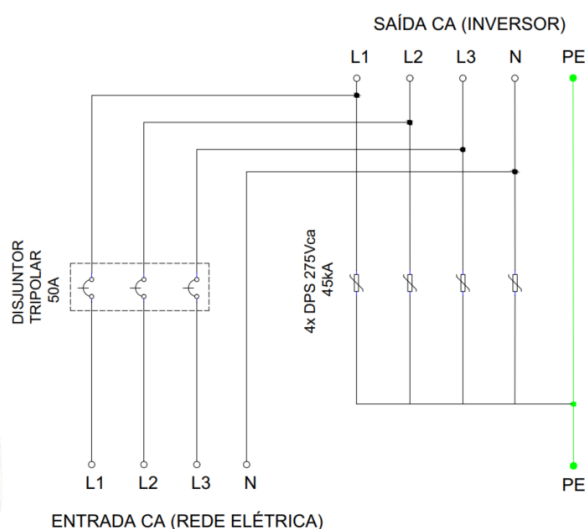
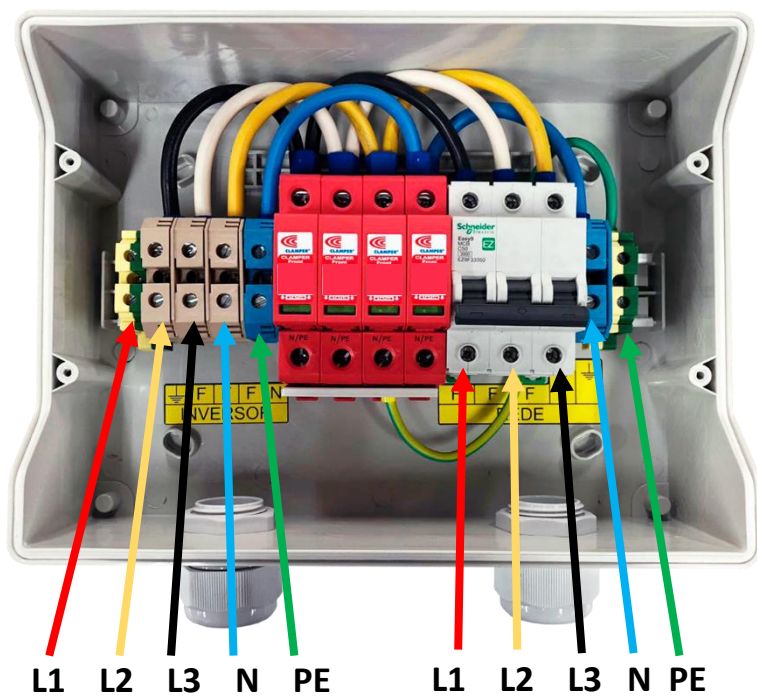

Rua São Bernardino nº 12  
Pq. Anhanguera - CEP: 05120-050  
São Paulo - SP



(11) 3648-7830  
contato@phb.com.br

